

# FORMAT AND BIT RATE INDEPENDENT COMMUNICATIONS OVER REGENERATED UNDERSEA FIBER OPTIC CABLE SYSTEMS

**Mark D. Tremblay**

Consultant: formerly at AT&T Labs and Tycom Labs

**Dr. Fred K. Duennebie**

Department of Geology and Geophysics, University of Hawaii

*Abstract* The recent retirement of many regenerated undersea fiber optic cable systems (mostly 280 and 560 Mbit/s) has presented an opportunity for cable re-use for some oceanic observatory applications. During their commercial lives, these systems transported internationally accepted standard multiplexed telecommunications formats. Using these types of formats in any form would require a substantial development effort and considerable line communications equipment at the observatory; both of which could render such cable re-use non-viable. This document presents a novel extremely simple and cost effective approach for carrying bit-format independent and bit rate independent (maximum rate less than one-half the line rate) signals over these systems. Terminal equipment modifications are, for all practical purposes, negligible; and, observatory line communications equipment is composed of single line regenerator (required in any approach) and a handful of components. The first application, the ALOHA Observatory off the coast of Oahu, will initially have a 100 Mbit Ethernet transport interface capability using this approach over one fiber pair. Although 100 Mbit is less than the maximum data rate that a fiber pair could carry, it is more than sufficient for ALOHA; a second fiber and a third pair can be brought into play if necessary; and, there is also the possibility of transporting more than one 100 Mbit Ethernet channel per fiber (two for 280 and up to four for 560 Mbit/s systems). Lastly, the original line terminal equipment (unaltered) is kept at the cable landing point to support line maintenance activities when required

## I. INTRODUCTION

A TDM (Time Division Multiplex) system, such as used on the 280/560 cable systems, involves both multiplexer and line transmission equipment. The line transmission equipment includes the transmission medium, numerous in-line regenerators, as well as, end terminal transmitters and receivers. The end terminal transmitters and receivers are, themselves, usually a variation of the in-line regenerators. By their nature, regenerated line systems operate at a fixed bit rate primarily determined by, but not limited to, a narrow band filter used in the regenerator timing recovery circuitry. Thus, regenerated line systems cannot be upgraded to a higher bit rate by simply changing equipment in the end terminals as can be done in more modern optically-amplified systems (improved technology can be utilized to increase the number of channels and/or bit rate). This is one of the

reasons that these older systems are being retired from commercial service

## II. SPECIFIC BACKGROUND

The earliest undersea fiber-optic transmission systems utilized TDM (Time Division Multiplexing) operating at multiples of 147.8 Mbit/s (each multiple carrying one 140 Mb traffic telecommunications channel) and were supplied by a number of vendors (various consortium-owned 147.8, 295.6 and 591.2 Mbit/s systems were deployed) [1]. Many of these early systems have been retired in favor of the more efficient state-of-the-art WDM (Wavelength Division Multiplex) systems. Some of these retired systems can now be re-used for non-telecommunications activities, such as, to provide both power and communications to undersea scientific observatories (for example, the ALOHA PROJECT). While providing power is relatively straightforward, communications can lead to a fairly expensive endeavor if one directly uses the terminal equipment as-is or devises similar multiplexing approaches.

## III. SIGNAL CHARACTERISTICS

The original line signal requirements, with respect to the line regenerators, fell into two categories: signal transmission and line supervision.

Signal transmission meeting acceptable error rates was accomplished via properly designed tandem regenerator links and end-terminal signal conditioning. End-terminal signal conditioning primarily involved:

*Keeping the line frequency tolerance within  $\pm 3$  ppm* (parts per million) (the regenerators can easily tolerate twice that deviation), and

Insuring a nominally 50% 1/0 transition density while minimizing the occurrence of long strings of "1"s and "0"s. This was primarily accomplished by utilizing a 7-bit pseudo-random bit-scrambler prior to transmission.

Line supervision was implemented via the addition of overhead line parity bits to:

measure the regenerator span parity error rate (an estimate of bit error rate), and

*communicate to the repeaters* (low bit-rate channel riding over some of the line parity bits) for performance

monitoring, fault-location and wet-plant redundancy switching. The repeater-to-terminal response channel was realized by phase modulating the line signal.

Note that while the end terminals incorporated line-frame formatting and multiplexing to transport telecommunications signal rates, the regenerated line system is actually transparent to the traffic being carried. In other words, data transport over the regenerated line requires only that the first two conditions stated above be met. On the other hand, line supervision requires that all the conditions indicated above be met. It should be noted that the line signal formats incorporated also included a number of low bit rate terminal-to-terminal maintenance communication channels which are only required in the telecommunications industry.

#### IV. RE-USE REQUIREMENTS

The requirements associated with the re-use of these retired systems are:

Ethernet signal transport at 10 Mbit/s or better; and

Maintain the line supervision capability.

The first requirement allows one to explore alternate signal processing methods in the interest of keeping implantation cost down while still meeting the line signal transmission requirements stated earlier. The second requirement can simple be met by retaining some of the end-terminal equipment associated with line supervision. Note that, unlike the telecommunications industry, data traffic transport and line supervision capabilities need not be operational concurrently. In other words, the re-use requirements can be met by connecting the end-terminal Ethernet transport equipment or the end-terminal line supervision equipment to the regenerated line as required. It is anticipated that observatory data loss because of the necessity to use line supervision functions would be negligible (less than 0.1% of the time) and mostly at predictable times.

#### V. DATA TRANSPORT MODULATOR

A very simple Data Transport Modulator can be designed that meets all three signal transmission requirements (Fig. 1a and Fig. 1b).

The **data** signal (actually, any binary data signal can be used) is sampled by the **line clock** signal to obtain the **sampled Data** signal (this introduces high-speed edge jitter effects which will be discussed later);

The **line clock** signal is divided by two to obtain a **half rate clock**;

The **sampled data** signal is used to Binary Phase-Shift Key [2] the **half rate clock** in the exclusively-OR ; and, finally,

The exclusive OR output signal is retimed to remove any **sampled data** and **half rate clock** transmission misalignments at the exclusive-OR inputs .

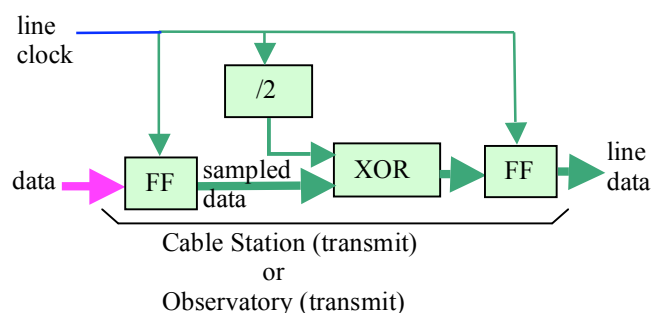

Figure 1a: Data Transport Modulator (FF = FlipFlop; XOR = Exclusive-OR)

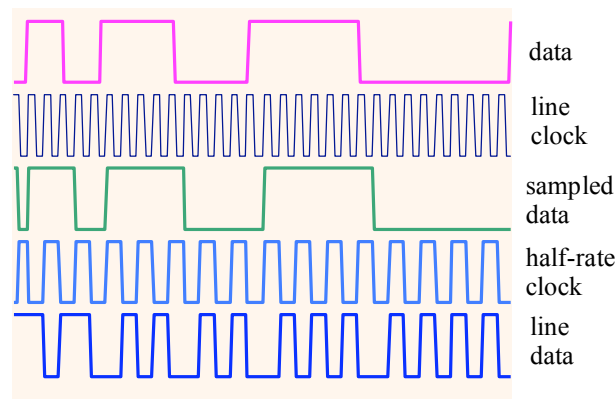

Figure 1b: Data Transport Modulator Signals

The resultant **line data** signal is essentially the **half-rate clock** with a phase reversal at the **sampled data** transitions. Thus, the **line data** signal has a 50% 1/0 transition density and no long strings of “1” or “0”. Another advantage of this approach is that line regenerator clock recovery performance is improved (reduced line timing jitter due to higher clock signal/noise ratio and no baseline wander effects). The expectation, then, is that the cable system itself will have little or no effect on the end-to-end data transport error rate.

The data demodulator (Fig. 2) performs the exact inverse functions. The last data re-clocking is added to remove any line edge jitter effects that may be introduced in the demodulation process. This then leaves only the sampling edge jitter effects introduced by the modulator plus a small amount of line regenerator induced timing jitter. Signal processing for the de-modulator is essentially the inverse of that shown in Fig. 1b.

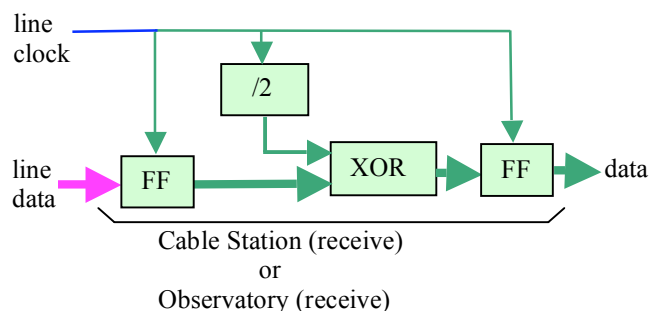

Figure 2: Data Transport De-modulator

**A. EDGE JITTER EFFECTS ON ETHERNET SIGNAL**

The modulator described above introduces high-speed (data bit-to-data bit) edge jitter (low speed jitter introduced by the line is expected to be negligible especially taking into consideration the improvement in regenerator clock recovery operation). The amount of data signal eye-closure (in time) is essentially the ratio of the Ethernet bit rate divided by the line rate. For example, the 100Base-TX (FX) data signal results in the eye closure amounts depicted in TABLE 1 (note that there are no 147.8 Mb/s systems retired to date; included for completeness only):

TABLE 1

DATA EYE CLOSURE DUE TO MODULATION APPROACH			
	System Line Rates (Mb/s)		
	147.8	295.6	591.2
100Base-TX (FX)*	85.6%	42.3 %	21.1 %
* : 100Base-TX, FX actually operates at 62.5 Mbit/s due to the 4B/5B coding (4- binary-bit sets encoded into 16 of the possible 32 5-binary-bit sets to minimize long strings of 1s and 0s followed by NRZI coding (Non-Return-to-Zero-Invert to reduce the maximum line data-signal frequency from 125 to 62.5 MHz.)			

The following simulated eye diagram (Fig. 3) shows the edge jitter timing effects for a 100Base-TX (FX) signal over a 295.6 Mb/s line (first application on PROJECT ALOHA). It can easily be observed that the time-dependent eye closure is about 3.5 ns (nanoseconds) or about 100 x (3.5 / 8) = 43.7% consistent with the previous calculation.

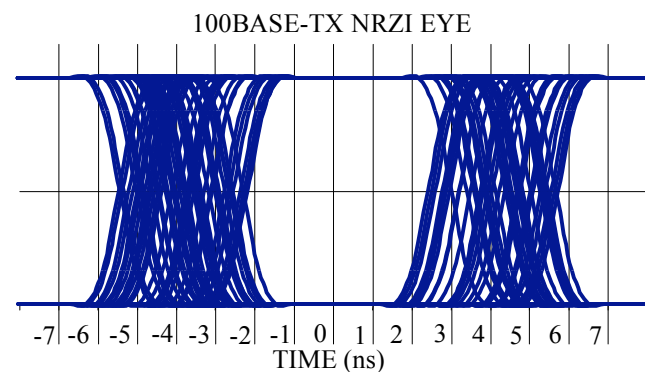

Figure 3: Simulated Sampled Data Eye Diagram

Note: The rise/fall times depicted in Fig. 3 are an artifact of the plotting process; however, they are representative of real-world devices.

Timing jitter introduced by the line itself is expected to be less than 0.004UI rms (Unit Intervals root-mean-square) per regenerator [1] and accumulates as a function of the square-root of the number of tandem regenerators. The value is from tests done with a  $(2^{23} - 1)$  bit pseudorandom sequence which has very long strings of 1s and 0s; actual line jitter using the modulation scheme described in this document would be at least a factor of two better. The following table shows the expected results

for a 100 regenerator system (50 outbound and 50 inbound) based on 0.004UI rms:

Note that the calculations shown can be considered the worst-case values for the previously mentioned reasons and include scaling down to the 100-Base-TX (FX) rate (line timing jitter translated to the data signal is reduced by the ratio of the bit rates).

TABLE 2

DATA EYE CLOSURE DUE TO RMS LINE JITTER (100 REGENERATORS)			
	System Line Rates (Mb/s)		
	147.8	295.6	591.2
100Base-TX (FX)*	3.4 %	1.7 %	0.8 %

The effects of line jitter on a 100Base-TX (FX) signal can be considered negligible (again, the 147.8 Mb/s system value is included only for completeness and would still result in functional transmission, albeit, with a smaller margin to errors).

**B. EYE DIAGRAM**

In the real world, eye diagrams exhibit both time and amplitude closure effects as shown in Fig; 4 for a 100Base-TX (FX) signal over a 295.6 Mb/s line. The eye closure is approximately 3.4 ns over the 8 ns bit period (42.5 %). The eye diagram in Figure 4 was shifted to the right slightly to show a complete bit period for a 1ns/cm scale.

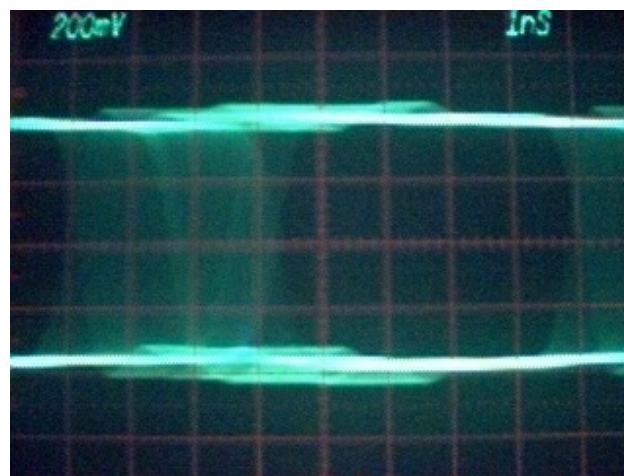

Figure 4: Measured 100Base-TX (FX) Eye Diagram

The test arrangement for the eye diagram measurement consisted of a bit error-rate test set running at a 125 MHz clock rate and a 1010 pattern to maximize the number of transitions for viewing and optical-to-electric converters and the modulator/demodulator circuit equipped with optical data interfaces (the modulator line data output signal was connected directly to the line data input).

**C. MODULATOR ERROR PERFORMANCE**

The retired undersea fiber systems operated, under non-fault conditions, at error rates better than  $10^{-13}$  (2 or 3 errors per day) with telecommunications traffic (from the author's experience). The much more benign data modulation scheme presented herein is expected to result

in even better error rates; effectively, one would not expect any errors from the undersea line itself.

There is also no expectation that the modulator will introduce any errors over its operating range. The operating range is limited at the low-end by the optical interface devices and at the high-end by the eye closure due the data rate approaching the sampling rate. The error performance shown in Figure 5 is for the initial prototype which presently has a slightly lower high-end performance due to power supply noise. As can be seen, the transport data rate requirement of at least 10 Mb/s is easily met. Figure 5 also shows that the 100Base-FX signal is comfortably in the middle of the operating range.

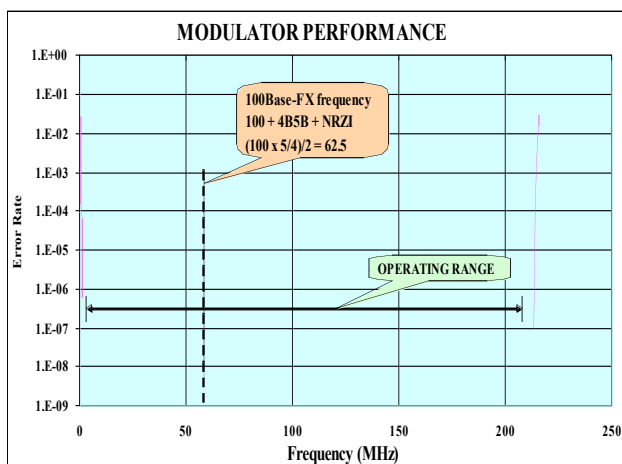

Figure 5: Modulator Performance (prototype)

## VI. DATA INVERSION IN THE RECEIVE DEMODULATOR

The data signal at the output of the receive de-modulator will be inverted 50% of the time since there is no information sent from the modulator indicating when to synchronize the de-modulator divide-by-two circuit. This nuance is not an issue for 100Base-TX/FX signals due to the NRZI (Non-Return-to-Zero Inverted) coding whereby transitions denote a "1" and no transition denotes a "0". Any utilization of signal sense dependent binary signals requires that the end user circuitry have the capability to accept either polarity. Note that the receive signal stays in either state and can only change if the signal is interrupted.

## VII. CONCLUSION

A method for transporting data rate independent signals over a TDM system without the need to develop costly multiplex equipment has been presented. While the focus was on transporting 100Base-TX (FX) Ethernet signals over retired submarine cable systems, the approach will work over any TDM system

## ACKNOWLEDGEMENTS

The authors would like to thank both AT&T and Tyco Electronics for technical information on the SL280/560 systems and AT&T for SL280/560 retired equipment. Thanks is given also to numerous engineering and technical personnel at the University of Hawaii at Manoa.

## REFERENCES

- [1] Peter K. Runge & Patrick R. Trishitta (editors), "Undersea Lightwave Communications", IEEE Press, 1986
- [2] Reference Data For Engineers: Radio, Electronics, Computer, & Communications, Eighth Edition, SAMS Publishing, 1995