

XSL-BCR-CCP-PBOF

PRESSURED BALANCED, OIL-FIELD SERIES

Material: Glass Reinforced Epoxy

Pressure Rating: 10,000 psi

*Also available in 2 5/8" Thread Length.

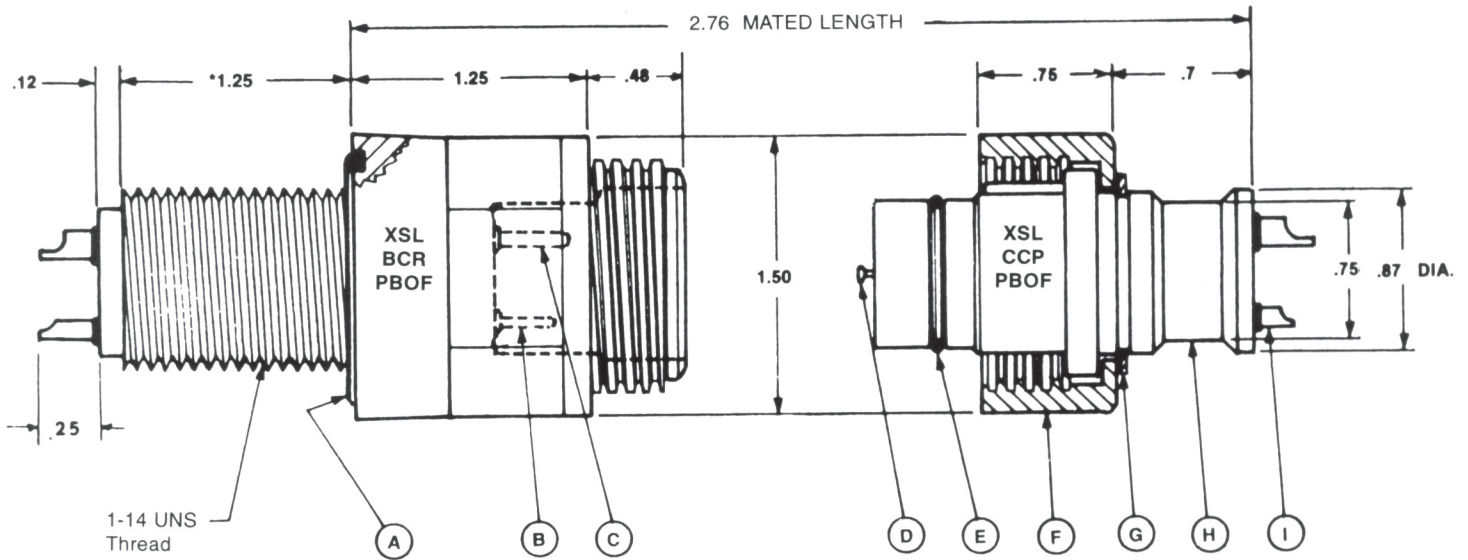

AVAILABLE CONTACT CONFIGURATIONS

- A - O-Ring 2-123
- B - Male Pin (small)
- C - Male Pin (large)
- D - Oil Compensating Valve
- E - O-Ring 2-017
- F - Engaging Nut
- G - Retaining Ring 5100-87H
- H - Diameter on body for tubing termination
- I - Solder Pots

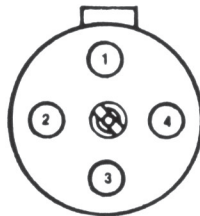

FRONT VIEW
XSL-4-CCP-PBOF
(4# 10 AWG)



FRONT VIEW
XSL-7-CCP-PBOF
(7# 16 AWG)



FRONT VIEW
XSL-12-CCP-PBOF
12 { 3# 16 AWG
9# 20 AWG

Note: Recommended Tubing Size: .75 ID
Tubing not supplied with parts unless specified.

New Available Configurations:

XSL-5-PBOF
(1 #14 AWG plus 4 #16 AWG).
Thread Length: 1"

XSL-8-PBOF
1 #14 AWG
7 #16 AWG

Note: Torque values referenced in this literature assume installation into dry metal threads. Please contact the factory for recommendations.