

TOLERANCES: (UNLESS SPECIFIED OTHERWISE) .X = ± .030 .XX = ± .010 .XXX = ± .005 A/B = ± .0625 X' = ± 1'	DRAWN Dave Copson	9/20/2006	University of Hawaii-SOEST		
	CHECKED				TITLE ALOHA STATION TEST HEAT SINK
	MFG		SIZE B	DWG NO testsink	
	APPROVED DC		SCALE	SHEET 1	OF 2

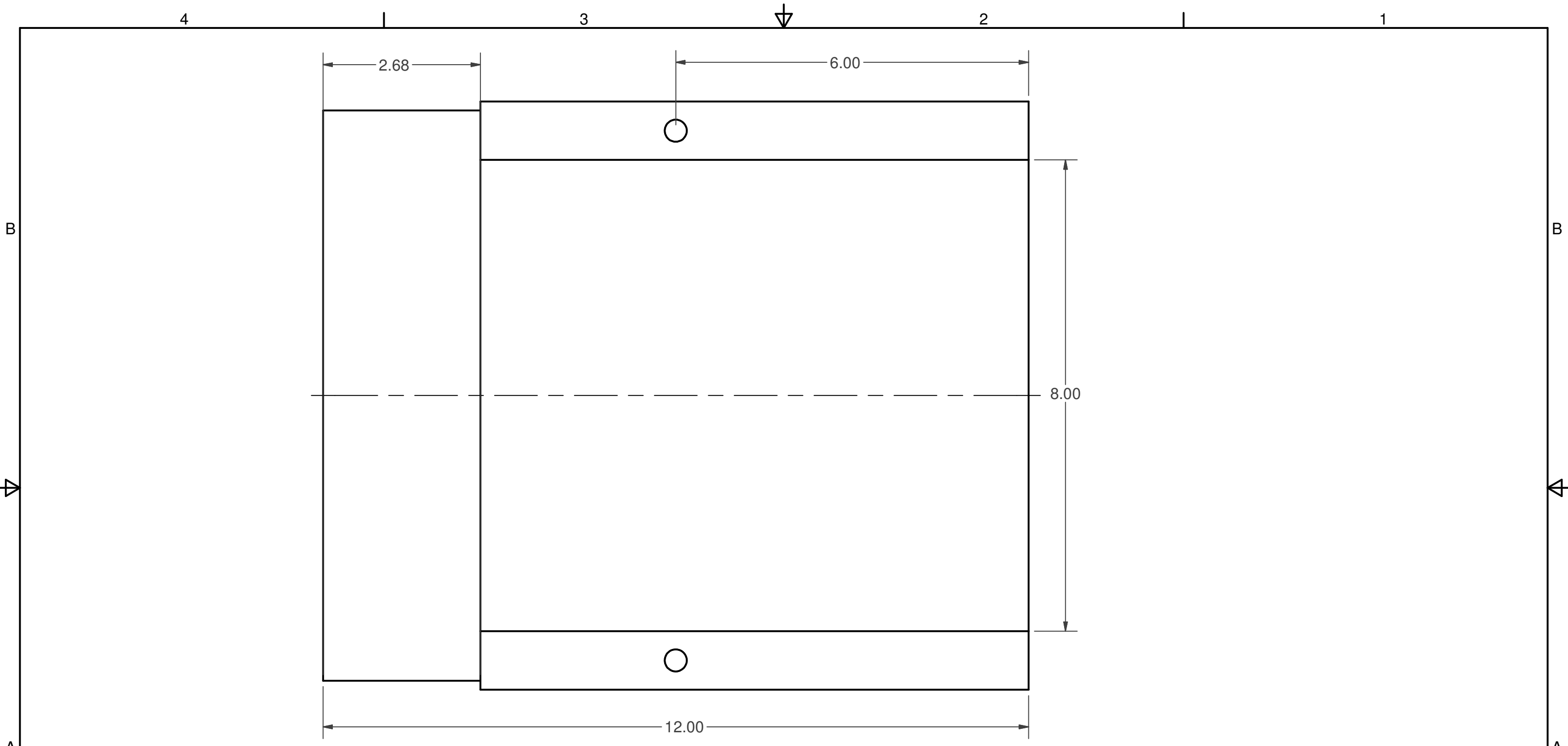

TOLERANCES: (UNLESS SPECIFIED OTHERWISE) .X = ± .030 .XX = ± .010 .XXX = ± .005 A/B = ± .0625 X' = ± 1'	DRAWN Dave Copson	9/20/2006	University of Hawaii-SOEST		
	CHECKED		TITLE		
	MFG		ALOHA STATION TEST HEAT SINK		
	APPROVED DC		SIZE B	DWG NO testsink	REV 0
			SCALE		SHEET 2 OF 2