

- NOTES:
- DO NOT SCALE FROM DRAWING.
 - FOR ITEM 1 OUTLINE/INTERFACE DIMENSIONS SEE D/N 18546 (ROV-025-03).
 - ALIGN MOLD RIB WITH RECEPTACLE KEY.
 - TEST CONNECTOR FOR ITEM 9 IS: IMPULSE CONNECTOR XSK-BCL.

UNCONTROLLED COPY
 COPY FOR INFORMATION ONLY
 WILL NOT BE KEPT UP TO DATE
 APPROVAL TO ISSUE LME DATE 7/20/06

REVISION	DESCRIPTION	DATE	APPROVED
A	CO 11088 INITIAL ISSUE	4-3-06	HAF
B	CO 12677	7-19-06	HAF

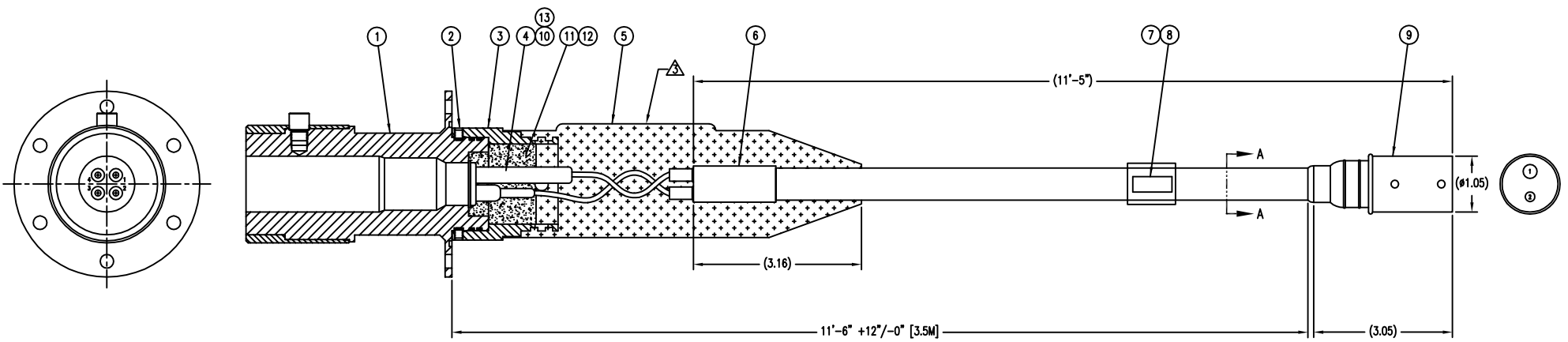
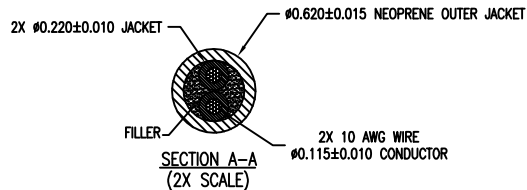

ITEM	PART #	REF #	DESCRIPTION	MATERIAL	QTY
13	1013221	PAN-030-04-1	SOLDER POT EXPANDER	BRASS	2
12	1009415	HD3561	EPOXY HARDENER	B.O.F.	A/R
11	1006024	EE4183	CASTING COMPOUND	HYSOL EPOXY	A/R
10	1012464	ODN-005-04-1	BOOT SEAL CAP	OD1037 RUBBER	2
9	1041703	RMK-FS	IMPULSE CONNECTOR (RMK-FS) W/ MOLDED CABLE	C.S.M.	1
8	1013374	P-TOUCH 1/2"	LABEL "ODI S/N ___"	B.O.F.	A/R
7	1013503	RNF-100 X 1"	CLEAR HEATSHRINK	B.O.F.	1 X A/R
6	1041691	COS-060-04	BREAKOUT BOOT SEAL	OD1037 RUBBER	1
5	1012002	NSD-062-04-3	POTTED TERMINATION	POLYURETHANE, AMBER	1
4	1008194	GBF-065-04-6	BOOT SEAL	OD1037 RUBBER	2
3	1016313	CTD-966-04-1	POTTING SLEEVE	ULTEM 2300	1
2	1001149	8-32 UNC X 3/16"	SOCKET HEAD SET SCREW	TITANIUM, COMM. PURE, GR. 2	8
1	1013629	ROV-023-01-4	4-WAY ROV BULKHEAD RECEPTACLE	VARIOUS (TITANIUM SHELL)	1
ITEM	PART #	REF #	DESCRIPTION	MATERIAL	QTY

PARTS LIST

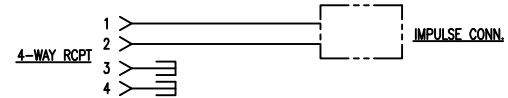

WIRING DIAGRAM

ALL DATA AND INFORMATION CONTAINED OR DISCLOSED BY THIS DOCUMENT IS CONFIDENTIAL AND PROPRIETARY INFORMATION OF OCEAN DESIGN, INC. AND ALL RIGHTS THEREIN ARE EXPRESSLY RESERVED. BY ACCEPTING THIS MATERIAL THE RECIPIENT AGREES THAT THE MATERIAL AND THE INFORMATION CONTAINED THEREIN IS HELD IN CONFIDENCE AND IN TRUST AND WILL NOT BE USED, COPIED, REPRODUCED IN WHOLE OR IN PART, NOR ITS CONTENTS REVEALED IN ANY MANNER TO OTHERS, EXCEPT TO MEET THE SPECIFIC PURPOSE FOR WHICH IT WAS DELIVERED.

UNLESS OTHERWISE SPECIFIED DIMENSIONS ARE IN INCHES. TOLERANCES ARE: ANGLES: ± 1/2° FRACTIONS: DECIMALS: ± 1/64 ± .005 ± .01 ± .003 SURFACE FINISH: CONCENTRICITY: .004 TIR THIRD ANGLE PROJECTION

ODI advanced technology systems
 OCEAN design, INC.
 www.odi.com

4-WAY ROV FXD RCPT TO MOLDED IMPULSE CONNECTOR GA DRAWING W/ PARTS LIST

APPROVALS	DATE	REV
DRAWN MWL	4/17/06	B
CHECKED MF	5-2-06	
ENGR HAF	5-2-06	
DESIGN		

SIZE B	CAGE CODE OVV88	DOC. NO. 92681	REV. B
SCALE FULL	PART NO. 1039637	REF. NO. COS-055-01	SHEET 1 OF 1