

| REVISIONS | | | |
|-----------|---------------------|------|----------|
| ZONE LTR | DESCRIPTION | DATE | APPROVED |
| | ISSUED FOR APPROVAL | | |
| | | | |
| | | | |

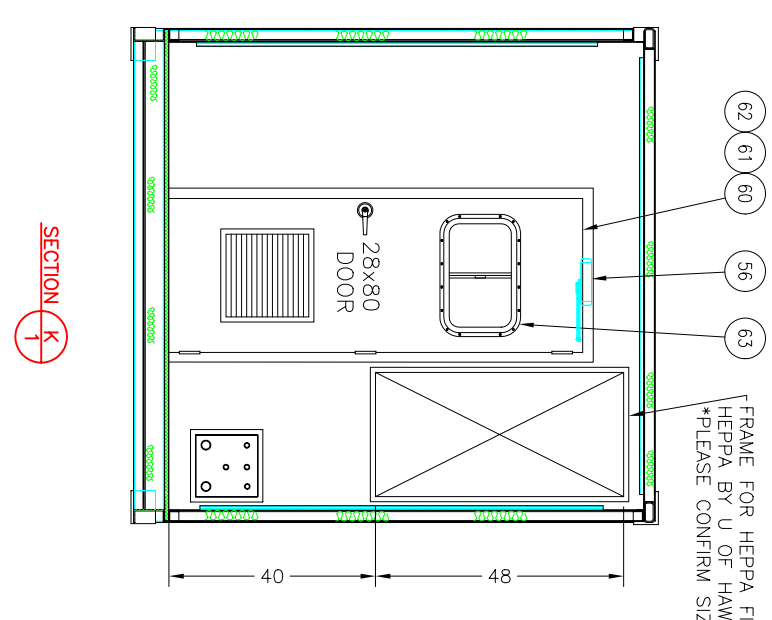
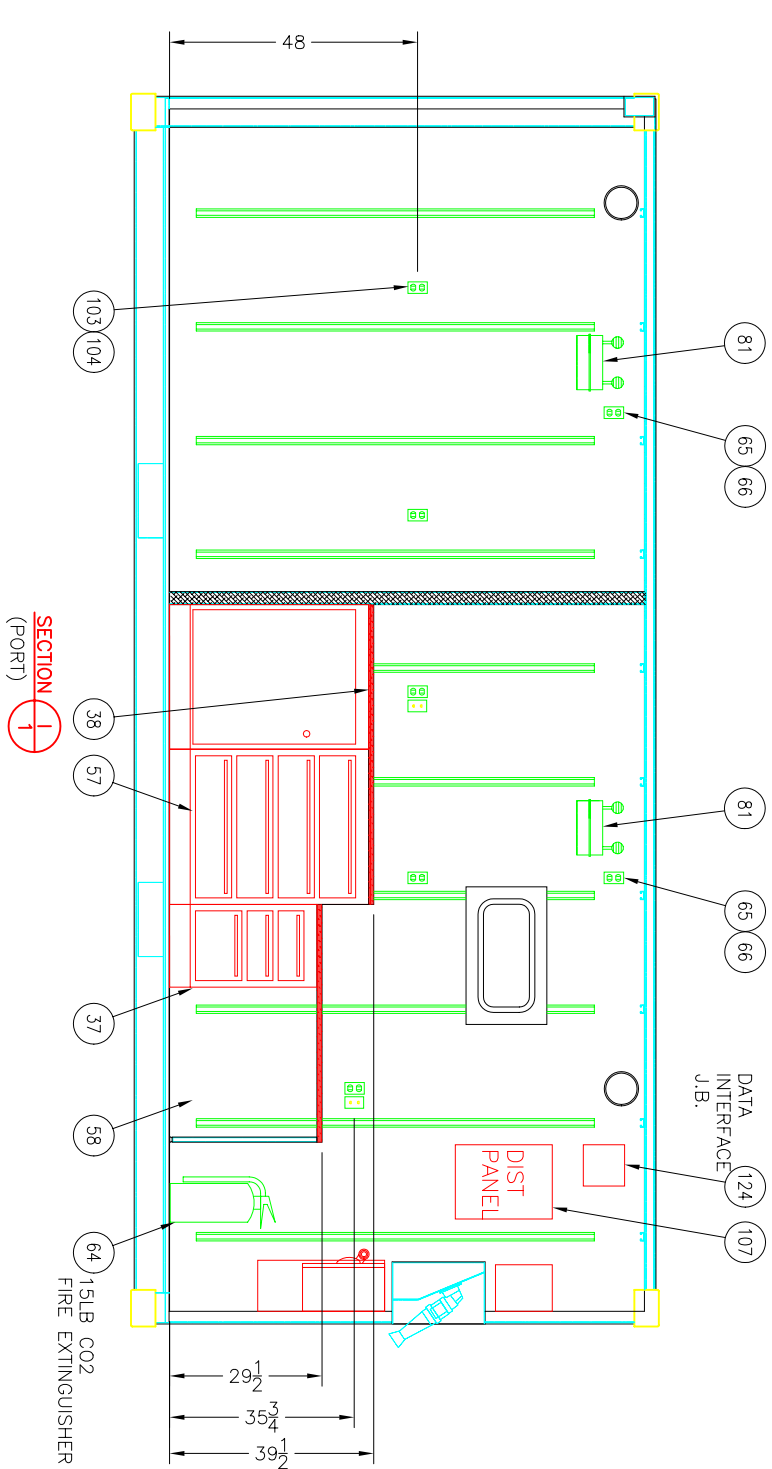
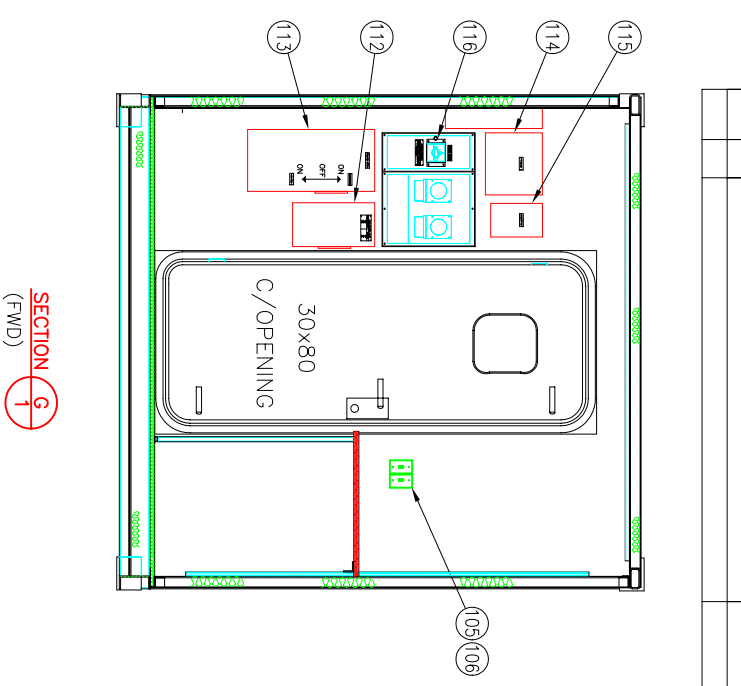
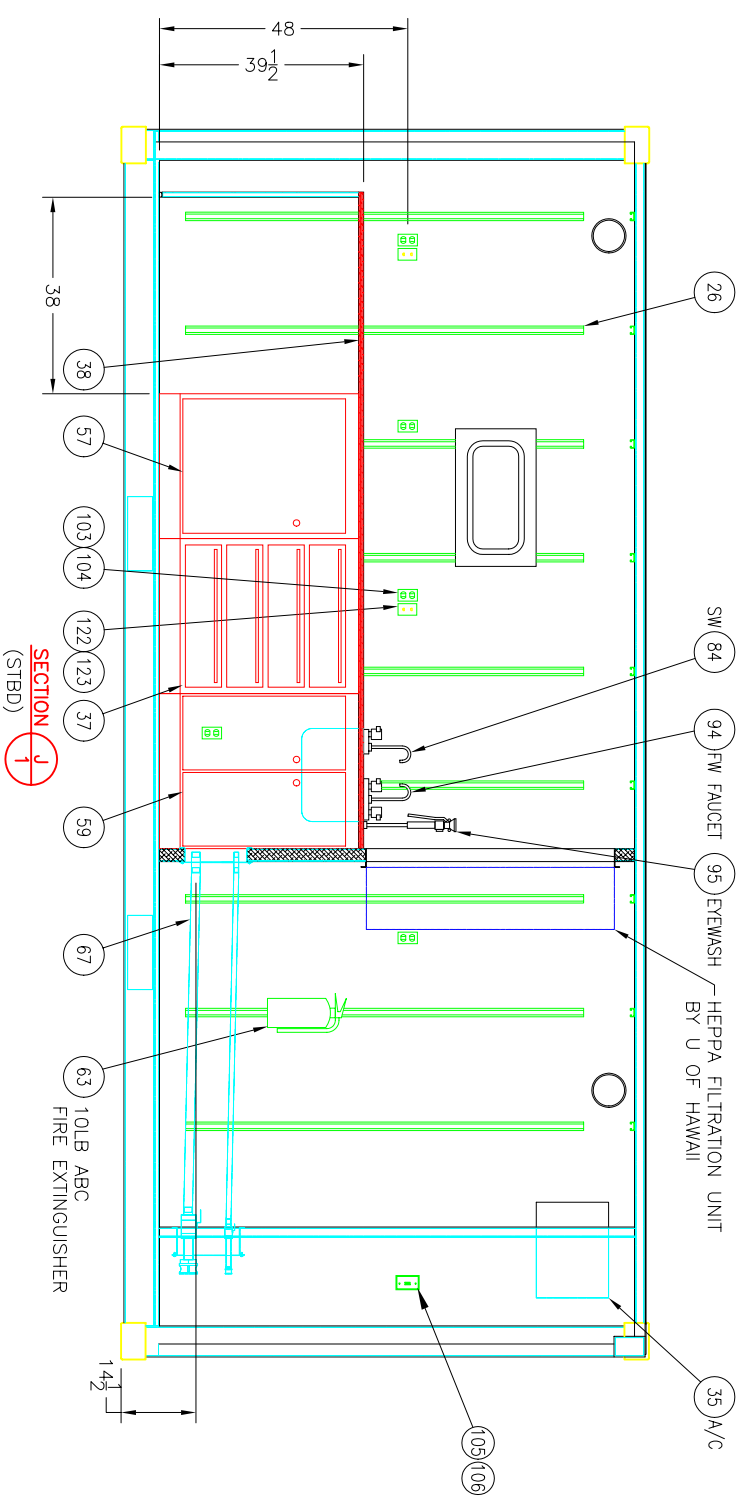
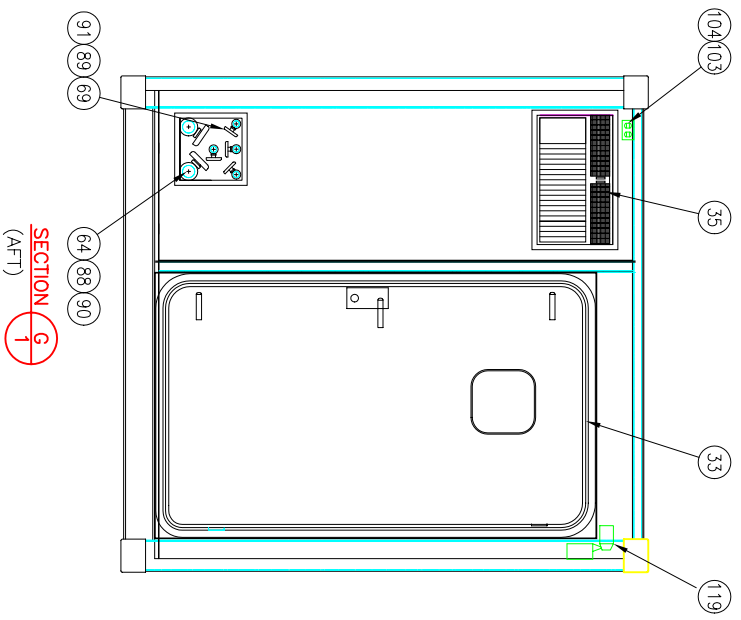

- NOTES:-
1. ALL ELECTRICAL WIRING TO BE SURFACE MOUNTED USING EMT
 2. MINIMUM WIRE SIZE IS TO BE #12AWG
 3. ALL CABLE/WIRE TO BE STRANDED, XLPE-90
 4. CONDUIT IS TO BE RUN ON THE WALL SURFACE AND NOT ON THE UNISTRUT.

THIS IS A PROPRIETARY DESIGN OF SONIC BARRIER SOUND PRODUCTS LTD. MANUFACTURE, REPRODUCTION OR USE OF ANY ASSEMBLY, SUBASSEMBLY OR PART IS NOT PERMISSIBLE EXCEPT IF EXPRESSLY PRIOR AUTHORIZED IN WRITING BY SONIC BARRIER SOUND PRODUCTS LTD.

| | | | |
|--|----------------------|-----------------|-------------|
| UNLESS OTHERWISE SPECIFIED DIMENSIONS ARE IN INCHES TOLERANCES | | CONTRACT No. | 592.3.01 |
| FRACTIONAL ± .01" | DECIMAL ± .001" | DRAWN | DAVE D. |
| ANGULAR ± 1° | DO NOT SCALE DRAWING | CHECK | |
| | | DESIGN | |
| | | DESIGN ACTIVITY | |
| | | CUSTOMER | U OF HAWAII |
| | | DATE | 6.FEB.03 |

| | | | |
|--------------|--|---|--------|
| TITLE | | 7973 PROGRESS WAY DELTA B.C. V4G 1A3 PH- 604 946-8100 FX- 604 946-6967 | |
| SIZE | | FSCM NO | DWG No |
| SCALE NTS | | 592301-02 | |
| RELEASE DATE | | SHEET 2 OF 5 | |
| REV. | | | |

INTERIOR VIEWS
ALUMINUM LAB VAN

